

OCULUS

Pentacam®
Pentacam® HR

The Gold Standard in
Anterior Segment Tomography



 OCULUS®

We focus on progress

Providing the best care to your patients

- > The eye is extremely sensitive.

Loss or impairment of sight is inconceivable for your patients.

- > Your patients appreciate the fast,
non-contact measurement.

You can establish a good doctor-patient relationship by showing the intuitive Pentacam® displays to your patients and discussing treatment options.

- > Your staff appreciate the ease of use and the seamless
connectivity to the electronic medical records.

- > The OCULUS Pentacam® wins patient trust.



Establish the basis for long term relationship with your patients.

Glaucoma screening

My eye doctor used a Pentacam® and identified that I am a glaucoma risk patient. I am very grateful that he checked my eye and discovered that I have a very small anterior chamber and a small angle.



Cataract surgery

Following a Pentacam® examination, my doctor showed me my cloudy lens. I was surprised that I could see anything at all! My doctor explained the operation using his PC. This gave me the sense of assurance I needed before the intervention.



Corneal surgery

I was happy with the quick Pentacam® examination and the competent consultation with my eye doctor. He showed me some Pentacam® images of my eye and explained the surgery in detail. I felt like I was in good hands with this physician.



Pentacam®

More than a topographer

First introduced in 1999, the Pentacam® is commercially available since 2003. It is the first automatically rotating Scheimpflug camera. During the rotating scan that takes max. 2 seconds, up to 50 Scheimpflug images of the anterior eye segment are captured. The examination is released automatically and is user independent. During the scanning process the patient's eye motions are captured using a second camera and compensated mathematically. Ray tracing is used to compensate for optical distortions. This combination is the basis for calculating solid data for further evaluation. More than 100 published studies and papers prove the efficiency of this concept.

The Pentacam® measures the cornea from limbus to limbus. It supplies topographic data on elevation and curvature of the entire anterior and posterior corneal surface. The corneal thickness (pachymetry) is measured and presented graphically over its entire surface. A topography based keratoconus detection and quantification are performed. The anterior chamber depth, chamber volume (size) and the chamber angles are calculated and presented for the Glaucoma screening. The illumination of the eye using blue LED light makes corneal and lens opacities (cataract) visible. For patients information the anterior chamber can be visualized and displayed with the virtual tomography model.

After the examination, Pentacam® provides an indice report that summarizes the abnormalities found during the scan. This report is based on clinical published studies and articles that define abnormalities. The Pentacam® can be customized with two software packages and several software modules to fit your exact needs. Basic software:

Basic Software:

- Qualitative assessment of the cornea
 - Topography and elevation data of the anterior and posterior corneal surface
 - Overall pachymetry, absolute and relative
- Glaucoma screening
 - Pachymetry based IOP correction
 - Chamber angle, -volume and -depth
- Topography based keratoconus detection and classification
- Indice Report to detect abnormalities
- Comparison and differential displays
- Superimposition of Scheimpflug images
- Tomography
- Automatic measurement of the corneal diameter HWTW



Now available with a new iris camera optic to provide the HWTW measurement automatically.

Pentacam® HR

The Professional Model

The Pentacam® HR produces sharp and brilliant images with its outstanding hardware. The high resolution CCD chip and optimized optic design measures up to 138,000 true elevation points. For a detailed analysis of the cornea up to 100 Scheimpflug images can be captured during the rotating scan. A moveable fixation target insures high ametropic patients a comfortable exam.

The high resolution Scheimpflug images of the Pentacam® HR impressively show the IOLs and pIOLs, as well as corneal rings, corneal injuries and corneal opacities such as, Fuchs dystrophy. The crystalline lens is displayed from its anterior capsule to the posterior capsule, even if opacities are present.

The Pentacam® HR is equipped with basic software and can be customized with two software packages and several software modules.

The unique 3D pIOL simulation software including aging prediction is available as an option.



This is what makes the HR special:

- Sharp Scheimpflug images to display corneal opacities, implants, rings etc.
- Sharp presentation of IOLs and pIOLs to determine position and detect PCO
- Special scan mode to display pIOLs
- Precise measurement of the cornea with up to 100 Scheimpflug images
- Moveable fixation target
- 3D pIOL simulation software including aging prediction

Now available with a new iris camera optic to provide the HWTW measurement automatically.



The comprehensive package



Keeping it organized – the drawer

The keyboard and the mouse can be stored neatly inside a slim and convenient drawer. There is also a nearly invisible docking station for the optional iPad 2.



Adjusting the height – the motorized table

The motorized table features illuminated up/down arrows, helpful in darkened examination rooms. The stylish silent table is patient-friendly and moves effortlessly.

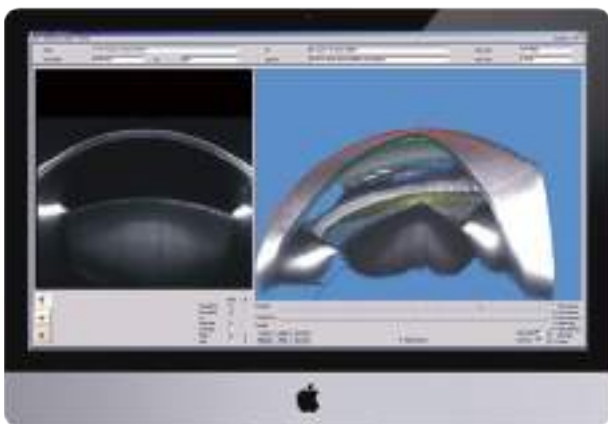

Impressively brilliant – the Apple iMac

The Apple iMac monitor displays the high resolution Scheimpflug pictures of the Pentacam® with optimal clarity. The examination results are even more vivid and impressive on the large LED backlit widescreen display.

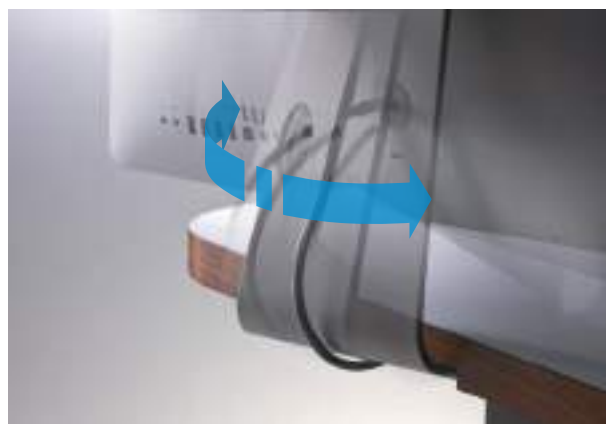

Fully integrated – sleek and ergonomic designs

The large screen can easily be slewed to the side. The iMac's stand is fully integrated into the table – shapely, functional and without tangled cables. This system is integration at its best.

Data Network

Physicians want a highly efficient practice and more time for patients. The Pentacam® offers both and comes with the patient data management software.

EMR compatibility

The Pentacam® software is compatible with many commercially available EMR systems.

DICOM compatibility

The Pentacam® software is fully DICOM compatible. The Pentacam® software receives information from the DICOM Modality Work List (MWL) from the Hospital Information System (HIS) and transmits the results to the Picture Archiving and Communication System (PACS) for storage and further evaluation.

Software licenses

In order to fully read and evaluate the Pentacam® exams at remote desktops, software licenses are required. The software license includes the Pentacam® Basic software. It is customizable and can be expanded to include additional software modules. With a software license, you can display and review any exam from any Pentacam® unit.



The cutting edge technology

The Pentacam® iPad-App



Easy, intuitive, and up-to-date

Pentacam® exams can be transferred to an iPad with the free Pentacam®-App.

OCULUS sets a new standard in patient consultation and information. The personal Pentacam® exams can be transferred to the patient's iPad too.



Pentacam® exams can be everywhere, whenever you need them.

Once the exams are transferred to an iPad, they are stored and can be reviewed easily.

Brilliant images

Precise measurements

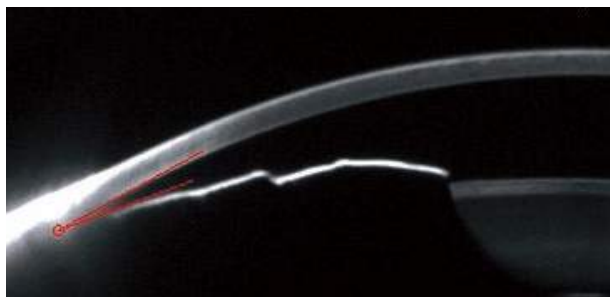

Glaucoma screening

The Pentacam® provides a comprehensive and completely automatic analysis of the anterior chamber. Immediately after the eye has been examined, the instrument displays whether the patient has an increased risk for glaucoma. Post-operative evaluation of the anterior chamber shows alterations, for example, after an iridectomy or other surgical interventions.



Cataract

The Scheimpflug images produced by the Pentacam® supply a clear representation of lens opacity. The 3D cataract analysis combined with the PNS (Pentacam® Nucleus Staging) is a unique feature. The center of the cornea and its anterior and posterior surfaces are measured very precisely for optimal calculation of the refractive corneal power. For your patients this means a perfect calculation of the IOL power – even after refractive surgery.



Cornea

The Pentacam® stands out by virtue of its high-resolution images and precise measurements for optimal surgical planning. Intelligent analysis programs help to substantiate your decisions. Surgical success is documented completely from start to finish. Even the smallest irregularities in the healing process are detected early. An examination using Pentacam® offers your patients the highest degree of safety.



Cataract/Refractive surgery

On the basis of measurements made by the Pentacam® one can determine whether the eye is suitable for surgical intervention or not. The surgery can be explained to the patient on the basis of the obtained results in clear and easy terms. In addition the Pentacam® offers the possibility to simulate in 3D the position of iris fixated phakic IOLs, including simulation of age-related growth of the crystalline lens. The selection of the aspheric IOL for purposes of reducing spherical aberrations is improved considerably by the unique corneal wavefront. The position of the implanted IOL can be located on the Scheimpflug image and assessed in detail in terms of centering and tilting.

Customizable The Software Packages

Refractive software package:

- Freely selectable reference bodies for elevation maps
- Overview display for refractive surgeons
- Corneal thickness progression analysis for early keratoconus detection
- Fourier Analysis Display
- Freely selectable four maps display
- Extended comparative and differential analysis of up to four examinations
- Side-by-side comparison of two examinations
- Side-by-side comparison of topometric and pachymetric data

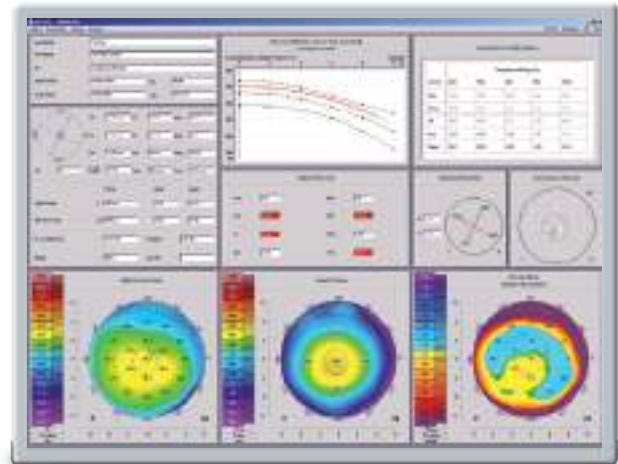

Cataract software package:

- True measurements in the Scheimpflug images
- Corneal Wavefront and Zernike analysis of the total cornea
- Cataract Pre-op display (developed in collaboration with Prof. Naoyuki Maeda, MD)
 - Detailed corneal assessment to select premium IOLs
- Power Distribution Display/Total Corneal Refractive Power
 - Improved IOL calculation
 - Orientation of toric IOLs
- True Net corneal power
- ✳️ PNS and 3D Cataract Analysis
- Extended comparative and differential analysis of up to four examinations
- Side-by-side comparison of two examinations
- Side-by-side comparison of topometric and pachymetric data
- Four maps, anterior chamber
- Four maps, topometric
- Anterior chamber depth map
- Anterior chamber angle in 360°, automatically

✳️ These functions are unique and are only available with the OCULUS Pentacam®

Basic software

Discover the Possibilities

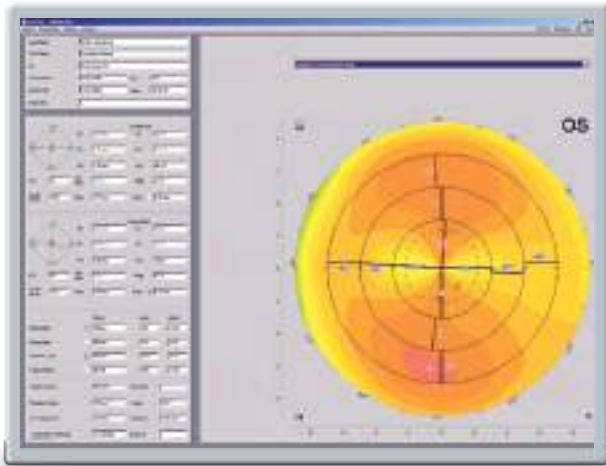

Topography Maps of the anterior and posterior corneal surface

Applications:

- Keratoconus detection
- Pre-surgical planning of refractive corneal surgery
- Follow-up after corneal surgery
- Calculation of IOL refractive power
- Planning of astigmatism-reducing incisions (LRI)
- Follow-up after refractive surgery
- (pre-post LASIK, PRK; PKP, LKP, DSEK)

Details:

The rotating measurement principle guarantees high resolution of the measuring points in the central cornea. Topographic analysis of the anterior and posterior corneal surfaces is based on the measured real height data. These provide the basis for:

- Sagittal (axial), tangential (local) curvature maps, refractive power maps of the anterior and posterior corneal surface
- Elevation maps of the anterior and posterior corneal surface
- Four color coded maps display for refractive assessment
- Topometric display for detailed corneal shape assessment including True Net Power
- Topography based keratoconus detection and classification
- Comparison and differential displays

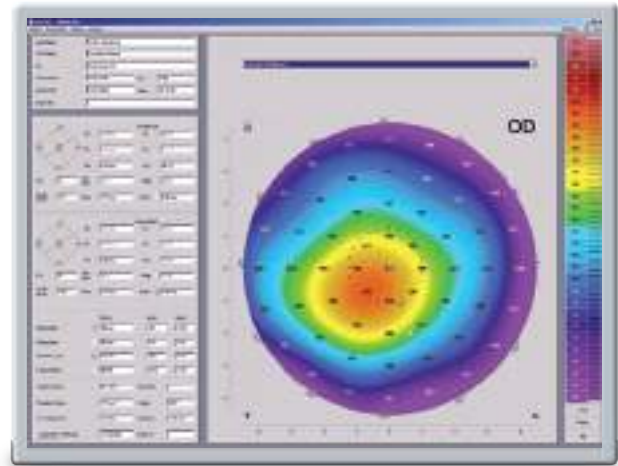

Pachymetry maps

Applications:

- Pre-surgical planning of refractive corneal surgery
- Absolute and relative presentation
- Glaucoma screening
- Relative pachymetry map for early keratoconus detection
- IOP correction taking into account measured corneal thickness based on various correction formulas (for e.g. Ehler, Shah, Dresden etc.)

Details:

An overview representation in color shows the corneal thickness from limbus to limbus. The measured values can be displayed in a pre-determined grid or represented manually at any point via mouse click.

Automatic representation of:

- corneal thickness in the centre of the pupil
- corneal thickness in the apex
- the thinnest point of the cornea



Iris Camera

Applications:

- overview image of the iris to recognize landmarks
- automatic determination of the corneal diameter (HWTW)
- determination of pupil location and shape

Details:

The Pentacam® as well as the Pentacam® HR are now equipped with an improved iris camera optic. The corneal diameter (HWTW) is calculated automatically from the iris photo and can be used for the selection and calculation of IOLs and pIOLs as well as for contact lenses.

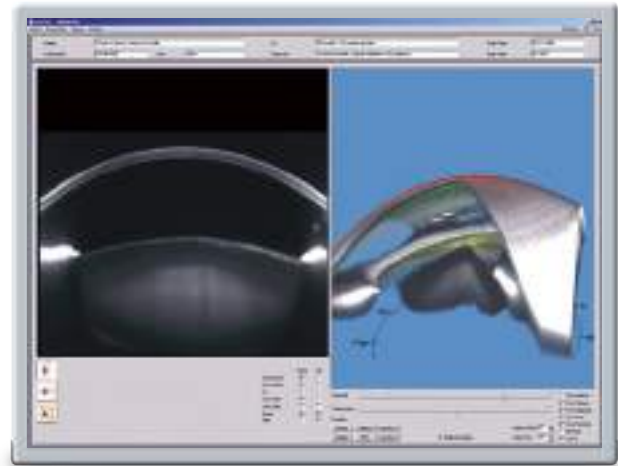

Anterior Segment Tomography ✖

Applications:

- Fast overview of gathered data
- Changes which become visible in the Scheimpflug image are represented amazingly well in a 3D model.

Details:

The rotatable and moveable 3D model of the anterior eye segment proves to be an enormous help in patient's education. The patient can see his eye from all sides. Irregularities can be explained easily in this way.

✖ These functions are unique and are only available with the OCULUS Pentacam®

Basic software

Discover the Possibilities

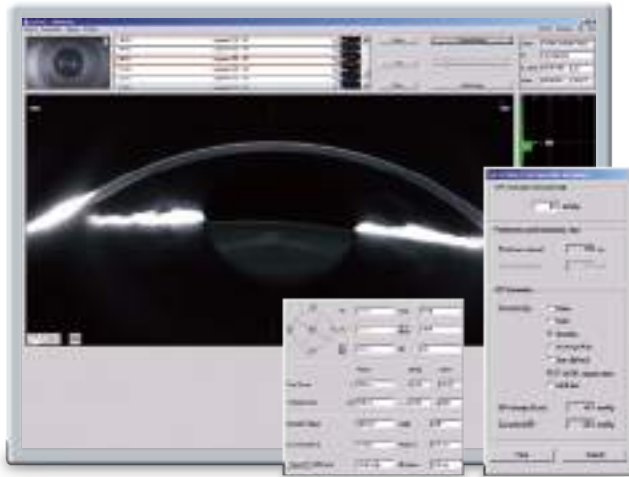

3D Anterior Chamber Analysis

Applications:

- Glaucoma screening
- Pre- to post-operative comparison of changes in anterior chamber, e.g. after Iridectomy

Details:

- Tomographic representation, virtual model of anterior segment
- Automatic calculation of
 - Anterior Chamber Angle (ACA)
 - Anterior Chamber Volume (ACV)
 - Anterior Chamber Depth (ACD), internal or external

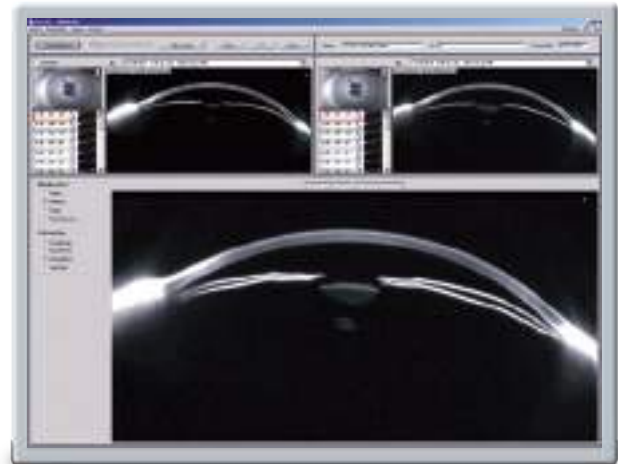

Superimposition of Scheimpflug images ✖

Applications:

- Comparison of the Scheimpflug images of two different exams
- Visualization of changes after surgical intervention
- Patient information – up-to-date

Details:

The superimposition of the Scheimpflug images includes a blending function to qualitatively visualize and analyze the changes in the anterior chamber.

Examples:

- Cornea, before and after LASIK
- Anterior chamber, before and after iridotomy
- Progression of lens opacifications (cataract)

Additional software modules



PNS and 3D Cataract Analysis ✖

Applications:

- ✖ Objective quantification of lens opacities (densitometry) in 2D and 3D
- ✖ Graduation of lens opacities (PNS)
 - Visualization of lens opacities
 - Visualization of posterior capsular opacities (PCO)
 - Representation of Bowman's membrane

Details:

Opacities of the natural lens are made visible by blue light illumination. The excellent quality of the Scheimpflug images allows automatic and objective quantification of lens opacities.

The PNS and 3D Cataract Analysis are part of the Cataract Package.

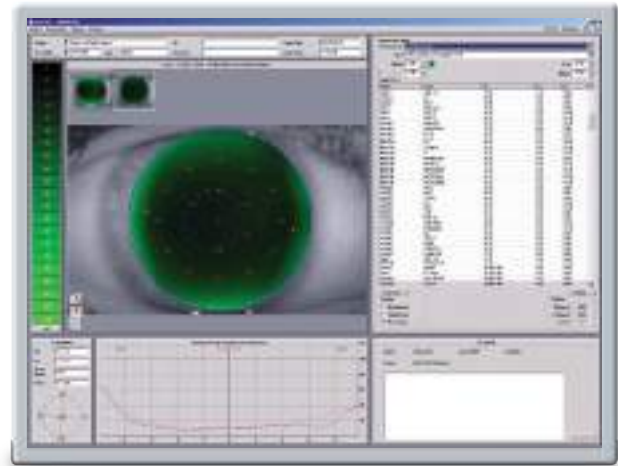

Contact Lens Fitting

Applications:

- Automatic display of all necessary measurement data for fitting contact lenses
- Automatic suggestions for contact lenses
- Realistic fluo image simulation
- Integrated and expandable contact lens database with over 65,000 lens geometries

Details:

With the dynamic fluo image simulation, the fit of the contact lens from the integrated database can be viewed. The simulation makes it possible to adjust inclination and to shift the contact lens while automatically making a new fluo image calculation. The integrated and expandable contact lens database contains over 65,000 lens geometries. The contact lens geometries can be adjusted individually in cases where fitting is difficult. The user can establish his own rating list for contact lens manufacturers and expand the database with new or further contact lenses.

✖ These functions are unique and are only available with the OCULUS Pentacam®

Additional software modules

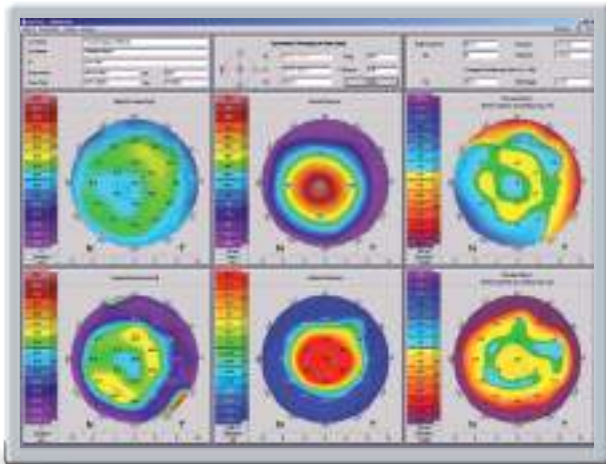

Holladay Report and Holladay EKR Report

Applications:

- Comprehensive clinical comparative representation
- EKR (Equivalent Keratometer Readings) for optimized IOL-calculation for post-refractive patient eyes, if no pre-op data are available

Details:

The Holladay Report was developed in collaboration with Jack T. Holladay, M.D.. It supplies data for calculating the optimal IOL refractive power for patients who have undergone refractive corneal surgeries such as LASIK and RK especially if no pre-op data are available. The Holladay Report calculates the real relationship of the posterior corneal surface to the anterior corneal surface. The overall refractive power of the cornea is calculated and described using the EKRs (Equivalent Keratometer Readings) in various zones. They can be used in IOL formulas, e.g. the Holladay 2.

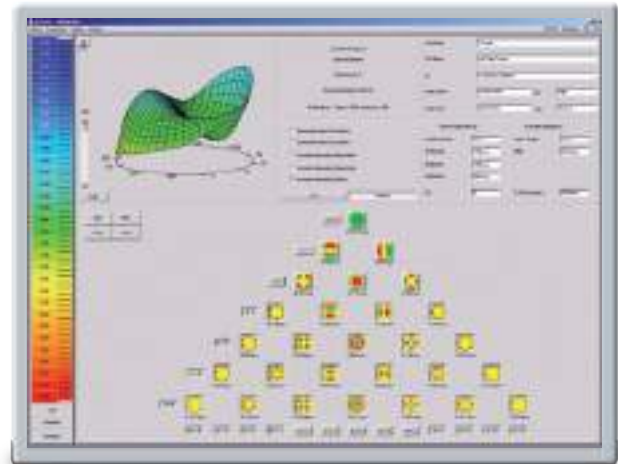

Corneal Wavefront Analysis

Applications:

- Selection of aspheric IOLs for correction of corneal spherical aberrations (Z4.0)
- Fitting of corneal rings in reference to the axis of the coma
- Determination of low and high order aberrations

Details:

The Zernike Analysis of the Pentacam® consists of two parts:

- The calculation of the corneal wavefront of the entire cornea (anterior and posterior surface) is performed via ray tracing – and is thus independent of the shape of the cornea (e.g. post LASIK, PRK, LKP, PKP etc).
- The surface based Zernike Analysis is performed using e.g. a theoretical, optimal corneal ellipse (ecc=0.751). It can be shown for the anterior and posterior surface of the cornea.

The Corneal Wavefront Analysis is part of the Cataract Package.

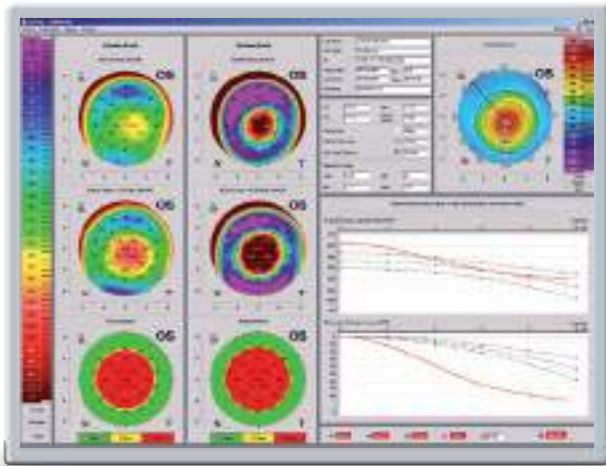

Belin/Ambrosio Enhanced Ectasia Display ✳

Applications:

- Minimizes "false positives" and "false negatives"
- Detection of keratoconus in very early stages

Details:

The Belin/Ambrosio Enhanced Ectasia display is the first screening tool which combines elevation data of the anterior and posterior corneal surface with corneal thickness progression analysis. It was developed in collaboration with Prof. Michael W. Belin, M.D. and Renato Ambrosio Jr., M.D..

Originally designed for myopic eyes it is now available for hyperopic eyes too. In addition to its overall more precise keratoconus detection this screening facilitates early detection in particular. The corneal thickness progression analysis is calculated using concentric rings, starting at the thinnest point and extending to the periphery. The evaluation of deviations from the standard elevation map and the enhanced elevation map is made easier by displaying the results in green, yellow and red.

Several single indices are individually calculated. They are then combined into one global index and displayed color coded.

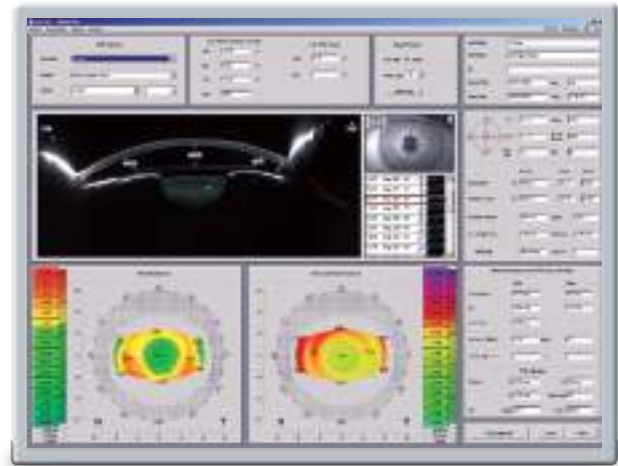

3D pIOL Simulation Software ✳

Applications:

- Pre-surgical planning of an iris-fixated pIOL (phakic Intra Ocular Lens)
- Simulation of post-operative position of the iris-fixated pIOL
- Simulation of age-related lens growth and the position of the iris-fixated pIOL resulting from this
- Patient selection

Details:

The examiner enters the data on the subjective refraction. Depending to the selected pIOL type, the software calculates the necessary refractive power using the van der Heyde formula. The examiner selects the pIOL from the current data bank accordingly. The position of this pIOL in the anterior chamber is automatically calculated in 3D and represented in the Scheimpflug images. The minimal distances between:

- the pIOL and the crystalline lens,
 - the pIOL and the endothelium
- are calculated automatically in 3D and displayed numerically and in a color map. The results can be shown to the patient. This software module is available for the Pentacam® HR only.

✳ These functions are unique and are only available with the OCULUS Pentacam®

Pentacam® Hardware



Pentacam® / Pentacam® HR

Basic software	●
Apple iMac 21"	○
Apple iMac 27"	○
Apple iPad 2	○
Design lift table	○
● included ○ optional	

Pentacam® HR Premium

Nothing left to be desired.

Software fully equipped (except pIOL)	●
Apple iMac 27"	●
Apple iPad 2	●
Premium design lift table	●
2 additional software licenses	●
● included ○ optional	

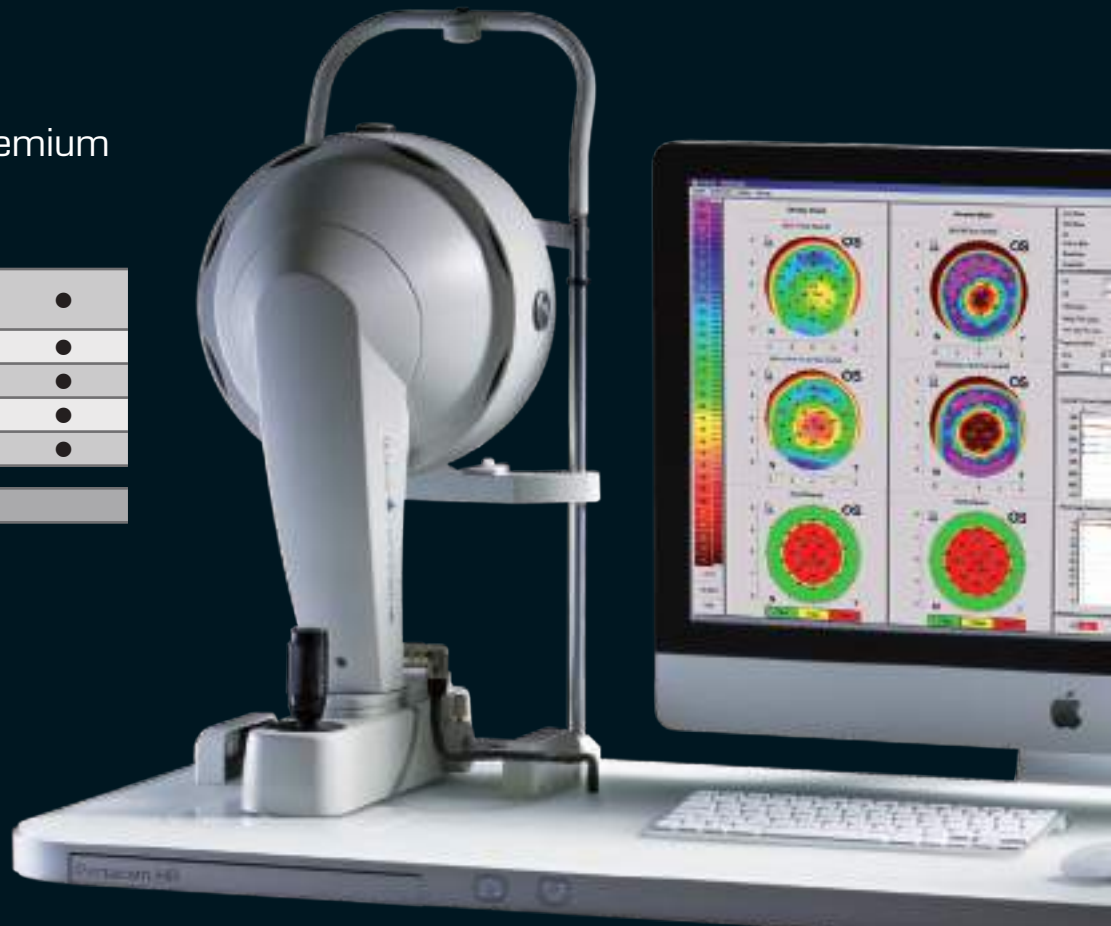

Pentacam® Software

Basic software	Pentacam®	Pentacam® HR	Pentacam® HR Premium
Overview of all captured Scheimpflug images	●	●	●
Topography maps of the anterior and posterior corneal surface	●	●	●
Pachymetry maps, absolute and relative	●	●	●
Elevation maps of the anterior and posterior corneal surface	●	●	●
3D Anterior chamber analysis	●	●	●
Anterior segment tomography	●	●	●
General overview display	●	●	●
Keratoconus detection and classification, topometrically	●	●	●
Four maps, refractive	●	●	●
Comparative and differential analysis of two examinations	●	●	●
Comparison and super imposition of Scheimpflug images	●	●	●
Optional software modules	Pentacam®	Pentacam® HR	Pentacam® HR Premium
Package Refractive	○	○	●
Package Cataract	○	○	●
Belin/Ambrosio Enhanced Ectasia	○	○	●
Holladay Report and Holladay EKR Detail Report	○	○	●
PNS and 3D cataract analysis	○	○	●
Contact lens fitting	○	○	●
3D pIOL simulation software including aging prediction	–	○	○
Optional hardware	Pentacam®	Pentacam® HR	Pentacam® HR Premium
21" iMac	○	○	–
27" iMac	○	○	●
iPad 2	○	○	●
Software licences	Pentacam®	Pentacam® HR	Pentacam® HR Premium
Additional software licences included	○	○	● (2)

● included ○ optional – not available

This is included in the packages:

Package Refractive:

- Freely selectable reference bodies for elevation maps
- Overview display for refractive surgeons
- Corneal thickness progression analysis for early keratoconus detection
- Fourier Analysis Display
- Four maps, freely selectable
- Side-by-side comparison of two examinations
- Extended comparative and differential analysis of up to four examinations
- Side-by-side comparison of topometric and pachymetric data

Package Cataract:

- Side-by-side comparison of two examinations
- Extended comparative and differential analysis of up to four examinations
- Side-by-side comparison of topometric and pachymetric data
- Power Distribution Display / Total Corneal Refractive Power
- Cataract pre-op Display
- Anterior chamber angle in 360°, automatically
- Four maps, anterior chamber
- Four maps, topometric
- Anterior chamber depth map
- True measurements in the Scheimpflug images
- Corneal wavefront and Zernike analysis of the total cornea
- True Net Power
- PNS and 3D cataract analysis

Technical Data

All Pentacam®-Models

Feature	Pentacam®	Pentacam® HR
Camera	digital CCD camera	digital CCD camera
Light source	blue LEDs (475 nm UV-free)	blue LEDs (475 nm UV-free)
Processor	DSP with 400 mil. operations/s	DSP with 400 mil. operations/s
Speed	50 images in 2 seconds ¹⁾	100 images in 2 seconds ²⁾
Dimensions (HxWxD)	535x280x360 mm	535x280x360 mm
Weight	9 kg	9 kg
PC minimum requirements	Pentium IV, 1.5 GHz, Windows XP, 1 GB RAM, VGA graphic card 1024 x 768 true colour, SB interface	Pentium IV, 1.5 GHz, Windows XP, 1 GB RAM, VGA graphic card 1024 x 768 true colour, SB interface

Measurement Range	Pentacam®	Pentacam® HR
Curvature	3 – 38 mm 9 – 99 D	3 – 38 mm 9 – 99 D
Precision	± 0,2 D	± 0,1 D
Reproducibility	± 0,2 D	± 0,1 D
Operating distance	80 mm	80 mm

¹⁾ Scheimpflug image of the entire anterior segment

²⁾ Cornea fine scan

CE in accordance with Medical Products Directive 93/42/EEC

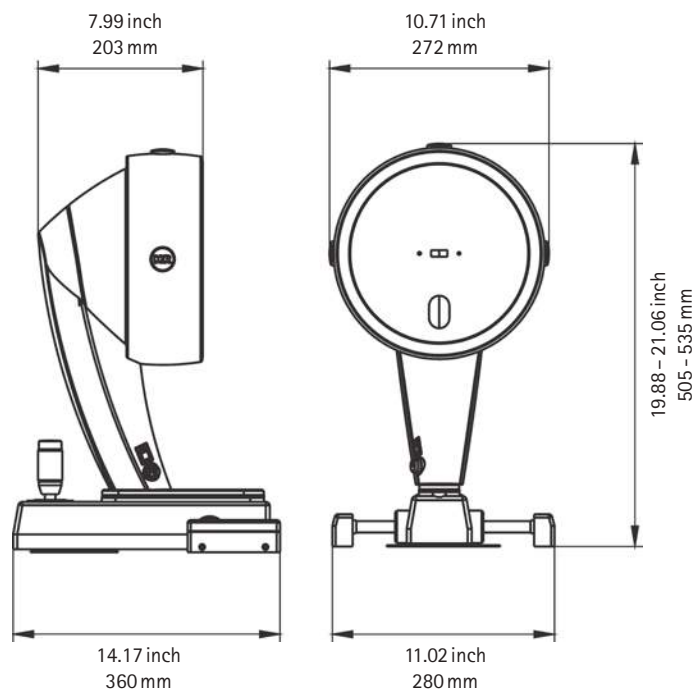

WWW.OCULUS.DE



OCULUS is certified by TÜV according to
DIN EN ISO 13485:2003/DIN EN ISO 9001:2000

OCULUS Optikgeräte GmbH

Postfach • 35549 Wetzlar • GERMANY

Tel. +49-641-2005-0 • Fax +49-641-2005-295

E-Mail: export@oculus.de • www.oculus.de

OCULUS Inc., USA

#112 • 2125 196th Street SW • Lynnwood • WA 98036

Toll free 1-888-284-8004 • Fax +1-425-670-0742

E-Mail: sales@oculususa.com • www.oculususa.com